

# NO-AUTOTEST EMERGENCY LIGHTING FOR RECESSED MOUNTING LEDLUX-SPOT2-V CINEMA



Escape Route Corridor Application "-A" version



Open Area Application "-B" version

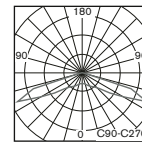
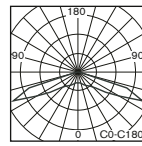
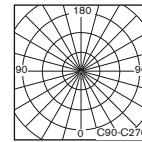
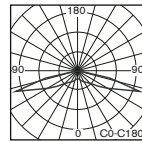
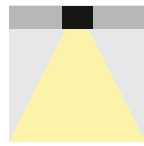

- Escape Route Corridor Application
- All "-A" versions
- Osvetlenie únikových ciest
- všetky "A" verzie

- Antipanic Open Area Application
- All "-B" versions
- Antipanic osvetlenie
- všetky "B" verzie

- Modern design orientated **recessed mounted LED** non-maintained/maintained (NM/M) emergency lighting especially designed for cinema / theatre applications
- Perfect light distribution **especially** designed for a **corridor applications (all versions "-A" - escape route illumination to EN1838) or open area antipanic (all versions "-B")**
- **AUTOTEST** function is deactivated to avoid testing (LED ON) during the movie or theatre performance

It is available in all following versions:

- **SELFCONTAINED (NO-AT)**
- **CENTRAL BATTERY (C.LEDLUX-SPOT2)** for **non-addressable CBS** (look up also page No.44)
- Conforming to the requirement of EN60598-2-22, EN1838, EN62034
- Design: plastic body in RAL9005 (black)

- Elegánnté stropné zapustené LED svietidlá pre **netrválé/trvalé (NM/M)** núdzové osvetlenie navrhnuté špeciálne pre použitie v kinách a divadlách (verzie "A" pre osvetlenie únikových ciest a koridorov a verzie "-B" antipanic osvetlenie pre otvorené priestory)

- **AUTOTEST** funkcia je deaktivovaná, aby sa zamedžilo nežiadúcemu rozsvieteniu LED počas predstavenia

Verzie:

- s **vlastnou batériou** (NO-AT, bez autotestu)
- **CENTRAL BATTERY (C.LEDLUX-SPOT2)** pre **neadresovateľné CBS** (str.44)
- spĺňa požiadavky európskej normy EN 60598-2-22, EN1838, EN62034
- konštrukcia: teleso z plastu vo farbe RAL9005 (čierna)

## STANDARD FEATURES

## ŠTANDARDNÁ VÝBAVA

- **High efficient HighPower (120lm/W) LONGLIFE LEDs >100.000h**
- **NEW Advanced Electronics**
- **LONGLIFE LiFePo4 battery**
- **Special LED lens** for perfect light distribution
- **Installation Mode** (battery protection, for more details look up page No.51+142)
- **Intelligent battery charging** (intermittent charging, look up page No.51+142)
- **DIP Switch** allowing to preset following functions:
  - **INSTALLATION MODE** activation/deactivation (look up page No.51+142)
  - **Maintained mode** activation/deactivation
- LEDs indicating presence of power supply and signaling failures & TEST button
- **vysoko účinné HighPower LED (120lm/W) so životnosťou min.100000h**
- **progresívna elektronická jednotka**
- **LONGLIFE LiFePo4 batéria**
- špeciálna LED šošovka pre perfektnú distribúciu svetla
- **Inštaláčny mód** (ochrana batérie, pozri aj str.51+142)
- **Inteligentné nabíjanie batérie** ("intermittent" nabíjanie, pozri aj str.51+142)
- **DIP prepínač** umožňujúci prednastavenie funkcií:
  - **Inštaláčny mód** aktivácia / deaktivácia (pozri aj str.51+142)
  - **trvalé núdzové osvetlenie** aktivácia / deaktivácia
- signalizácia LED a TEST tlačítko

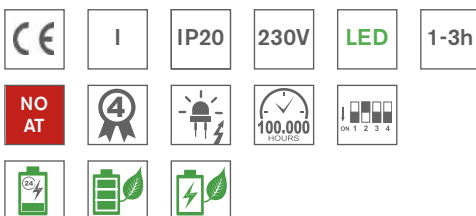

### Input Power:

- 5,5W/ 5,7VA (maintained M)
- 1,9W/ 4,0VA (non-maintained NM)
- 3,5W/ 4,6VA (CBS)

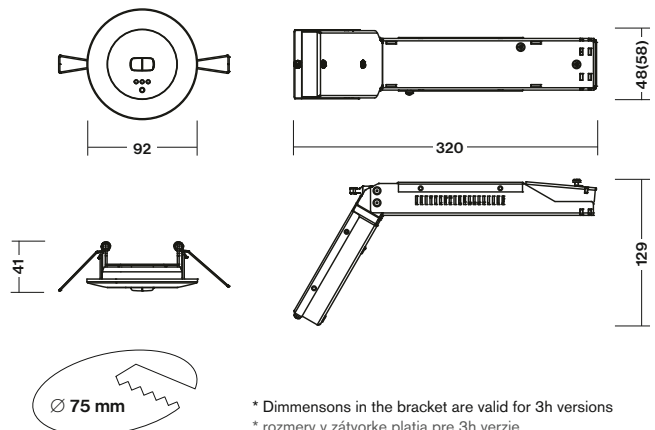

\* Dimmensions in the bracket are valid for 3h versions  
\* rozmery v zátvorke platia pre 3h verzie

# NO-AUTOTEST EMERGENCY LIGHTING LEDLUX-SPOT2-V CINEMA

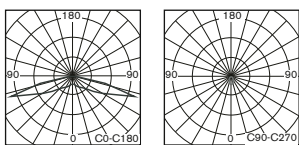
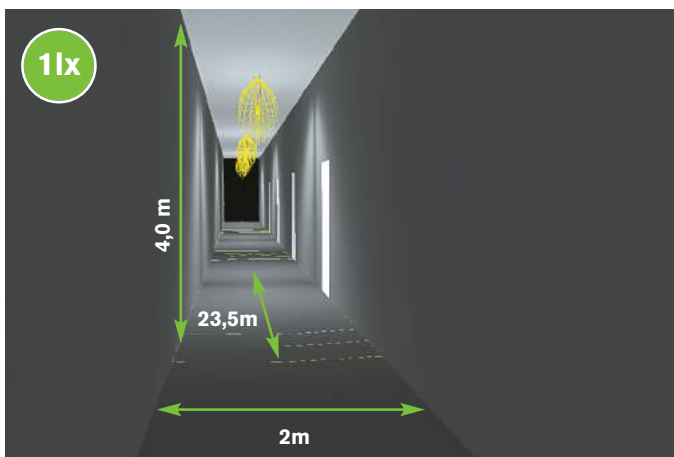

- Escape Route Corridor Application
- All "A" versions
- Osvetlenie únikových ciest
- všetky "A" verzie

1LX SPACING TABLE / ROZMIESTNENIE PRE 1LX		
H (m)	Y1 (m)	Y2 (m)
2,75	8,3	20,1
3,00	8,4	20,9
3,50	7,9	22,5
4,00	7,7	23,5
4,50	7,1	23,1
5,00	6,4	21,9

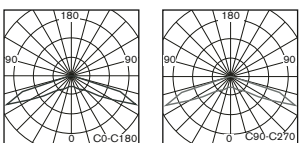
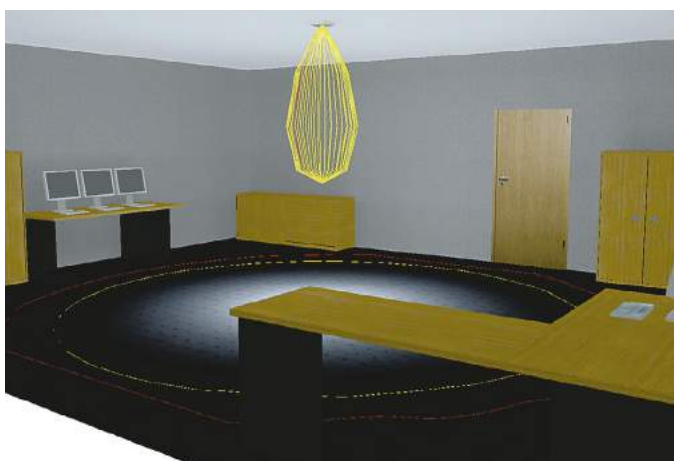
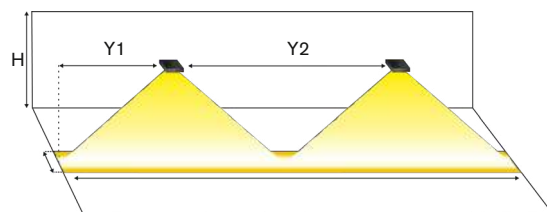

- Antipanic Open Area Application
- All "B" versions
- Antipanic osvetlenie "otvorené" priestory
- všetky "B" verzie

1LX SPACING TABLE / ROZMIESTNENIE PRE 1LX				
H (m)	X1 (m)	X2 (m)	Y1 (m)	Y2 (m)
2,75	3,8	12,6	3,8	12,6
3,00	3,3	12,7	3,3	12,7
3,50	2,5	11,8	2,5	11,8
4,00	1,8	10,1	1,8	10,1

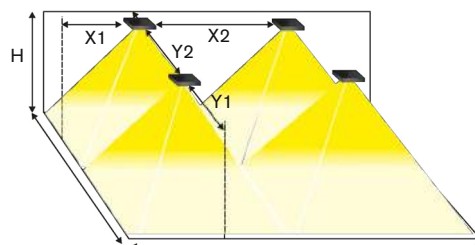

## NO-AUTOTEST NM/M

Type	Colour	Light Source	Light Flux / Emergency mode	Battery	Order Code	Weight
MULTILED-SPOT2-A-V.1h <b>NO-AT</b>	Black / čierna	HighPower LED	150 lm / 150 lm	LiFePo4 6,4V/1,0Ah	182-B-328-04-00-03	0,6 kg
MULTILED-SPOT2-B-V.1h <b>NO-AT</b>	Black / čierna	HighPower LED	150 lm / 150 lm	LiFePo4 6,4V/1,0Ah	182-B-329-04-00-03	0,6 kg
MULTILED-SPOT2-A-V.3h <b>NO-AT</b>	Black / čierna	HighPower LED	150 lm / 150 lm	LiFePo4 6,4V/2,0Ah	182-B-331-04-00-03	0,7 kg
MULTILED-SPOT2-B-V.3h <b>NO-AT</b>	Black / čierna	HighPower LED	150 lm / 150 lm	LiFePo4 6,4V/2,0Ah	182-B-332-04-00-03	0,7 kg

Page No.44

## CENTRAL BATTERY (CBS)

Type	Colour	Version	Light Source	Light Flux	Order Code	Weight
C.LEDLUX-SPOT2-A-V 230V AC/DC	Black / čierna	CBS NON-ADDRESSABLE	HighPower LED	150 lm	182-B-333-00-00-03	0,5 kg
C.LEDLUX-SPOT2-B-V 230V AC/DC	Black / čierna	CBS NON-ADDRESSABLE	HighPower LED	150 lm	182-B-334-00-00-03	0,5 kg

Look up pages No. 210-217 for 1lx Spacing tables  
Pozri str.210-217 pre rozmiestnenie svetidiel na dosiahnutie 1lx

# NO-AUTOTEST EMERGENCY LIGHTING FOR SURFACE MOUNTING LEDLUX-SPOT2-P CINEMA

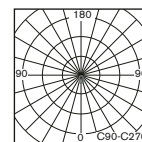
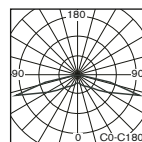

- Escape Route Corridor Application
- All "A" versions
- Osvetlenie únikových ciest
- všetky "A" verzie

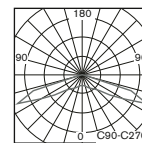
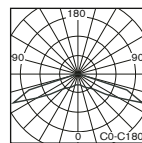

- Antipanic Open Area Application
- All "B" versions
- Antipanic osvetlenie
- všetky "B" verzie



Escape Route Corridor Application "A" version



Open Area Application "B" version

- Modern design orientated **surface mounted LED** non-maintained/maintained (NM/M) emergency lighting especially designed for cinema / theatre applications
- Perfect light distribution **especially** designed for a **corridor applications (all versions "A" - escape route illumination to EN1838) or open area antipanic (all versions "B")**
- **AUTOTEST** function is deactivated to avoid testing (LED ON) during the movie or theatre performance

It is available in all following versions:

- **SELFCONTAINED (NO-AT)**
- **CENTRAL BATTERY (C.LEDLUX-SPOT2)** for **non-addressable CBS** (look up also page No.44)
- Conforming to the requirement of EN60598-2-22, EN1838, EN62034
- Design: plastic body in RAL9005 (black)

- Elegánnté stropné prisadené LED svietidlá pre **netrválé/trvalé (NM/M) núdzové osvetlenie navrhnuté špeciálne pre použitie v kinách a divadlách (verzie "A" pre osvetlenie únikových ciest a koridorov a verzie "B" antipanic osvetlenie pre otvorené priestory)**

- **AUTOTEST** funkcia je deaktivovaná, aby sa zamedžilo nežiadúcemu rozsvieteniu LED počas predstavenia

Verzie:

- s **vlastnou batériou** (NO-AT, bez autotestu)
- **CENTRAL BATTERY (C.LEDLUX-SPOT2)** pre **neadresovateľné CBS** (str.44)
- spĺňa požiadavky európskej normy EN 60598-2-22, EN1838, EN62034
- konštrukcia: teleso z plastu vo farbe RAL9005 (čierna)

## STANDARD FEATURES

## ŠTANDARDNÁ VÝBAVA

- **High efficient HighPower (120lm/W) LONGLIFE LEDs >100.000h**
- **NEW Advanced Electronics**
- **LONGLIFE LiFePo4 battery**
- **Special LED lens** for perfect light distribution
- **Installation Mode** (battery protection, for more details look up page No.51+142)
- **Intelligent battery charging** (intermittent charging, look up page No.51+142)
- **DIP Switch** allowing to preset following functions:
  - **INSTALLATION MODE** activation/deactivation (look up page No.51+142)
  - **Maintained mode** activation/deactivation
- LEDs indicating presence of power supply and signaling failures & TEST button
- **vysoke účinné HighPower LED (120lm/W) so životnosťou min.100000h**
- **progresívna elektronická jednotka**
- **LONGLIFE LiFePo4 batéria**
- špeciálna LED šošovka pre perfektnú distribúciu svetla
- **Inštalčný mód** (ochrana batérie, pozri aj str.51+142)
- **Inteligentné nabíjanie batérie** ("intermittent" nabíjanie, pozri aj str.51+142)
- **DIP prepínač** umožňujúci prednastavenie funkcií:
  - **Inštalčný mód** aktivácia / deaktivácia (pozri aj str.51+142)
  - trvalé núdzové osvetlenie aktivácia / deaktivácia
- signalizácia LED a TEST tlačítko

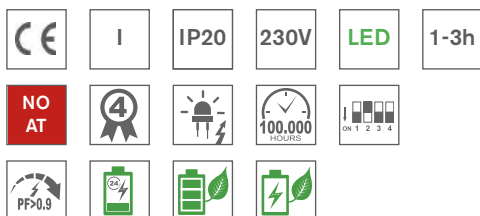

### Input Power:

- 5,5W/ 5,7VA (maintained M)
- 1,9W/ 4,0VA (non-maintained NM)
- 3,5W/ 4,6VA (CBS)

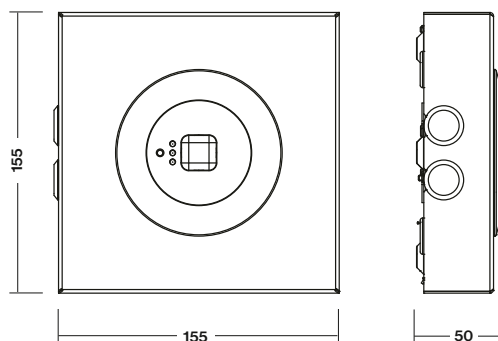

# NO-AUTOTEST EMERGENCY LIGHTING FOR SURFACE MOUNTING LEDLUX-SPOT2-P CINEMA

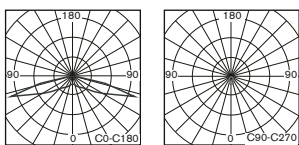
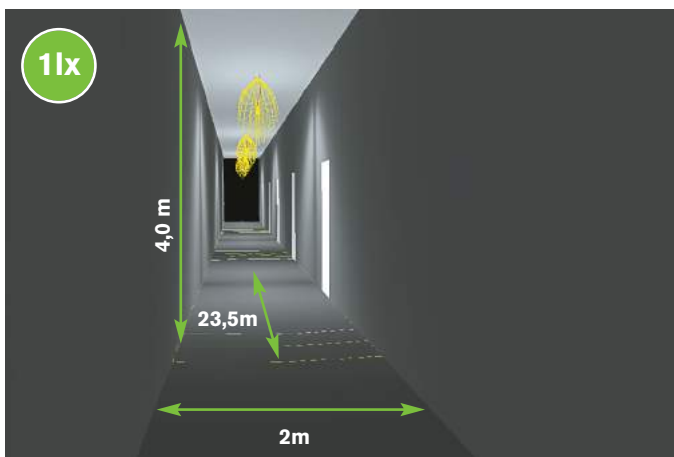

- Escape Route Corridor Application
- All "A" versions
- Osvetlenie únikových ciest
- všetky "A" verzie

1LX SPACING TABLE / ROZMIESTNENIE PRE 1LX		
H (m)	Y1 (m)	Y2 (m)
2,75	8,3	20,1
3,00	8,4	20,9
3,50	7,9	22,5
4,00	7,7	23,5
4,50	7,1	23,1
5,00	6,4	21,9

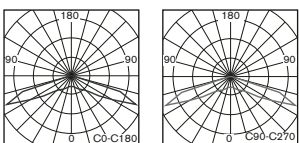
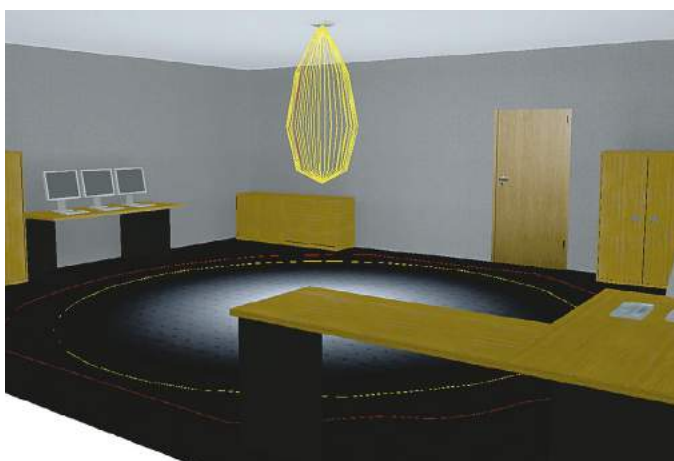
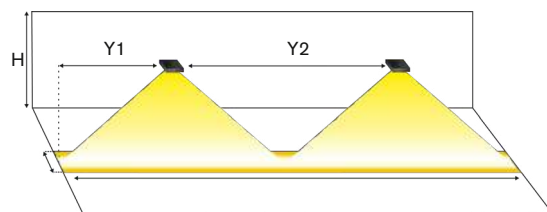

- Antipanic Open Area Application
- All "B" versions
- Antipanic osvetlenie "otvorené" priestory
- všetky "B" verzie

1LX SPACING TABLE / ROZMIESTNENIE PRE 1LX				
H (m)	X1 (m)	X2 (m)	Y1 (m)	Y2 (m)
2,75	3,8	12,6	3,8	12,6
3,00	3,3	12,7	3,3	12,7
3,50	2,5	11,8	2,5	11,8
4,00	1,8	10,1	1,8	10,1

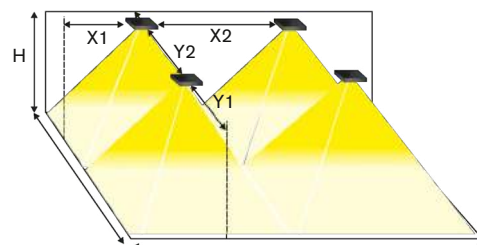

## NO-AUTOTEST NM/M

Type	Colour	Light Source	Light Flux / Emergency mode	Battery	Order Code	Weight
MULTILED-SPOT2-A-P.1h <b>NO-AT</b>	Black / čierna	HighPower LED	150 lm / 150 lm	LiFePo4 6,4V/1,0Ah	182-B-233-04-00-03	0,6 kg
MULTILED-SPOT2-B-P.1h <b>NO-AT</b>	Black / čierna	HighPower LED	150 lm / 150 lm	LiFePo4 6,4V/1,0Ah	182-B-234-04-00-03	0,6 kg
MULTILED-SPOT2-A-P.3h <b>NO-AT</b>	Black / čierna	HighPower LED	150 lm / 150 lm	LiFePo4 6,4V/2,0Ah	182-B-235-04-00-03	0,7 kg
MULTILED-SPOT2-B-P.3h <b>NO-AT</b>	Black / čierna	HighPower LED	150 lm / 150 lm	LiFePo4 6,4V/2,0Ah	182-B-236-04-00-03	0,7 kg

Page No.44

## CENTRAL BATTERY (CBS)

Type	Colour	Version	Light Source	Light Flux	Order Code	Weight
C.LEDLUX-SPOT2-A-P/230V AC/DC	Black / čierna	CBS NON-ADDRESSABLE	HighPower LED	150 lm	182-B-238-00-00-03	0,5 kg
C.LEDLUX-SPOT2-B-P/230V AC/DC	Black / čierna	CBS NON-ADDRESSABLE	HighPower LED	150 lm	182-B-238-00-00-03	0,5 kg

Look up pages No. 210-217 for 1lx Spacing tables  
Pozri str.210-217 pre rozmiestnenie svetidiel na dosiahnutie 1lx